

## Table of Contents

	Page
<b>1. Data Sheet .....</b>	<b>2</b>
<b>2. Initial Operation .....</b>	<b>3</b>
2.1. Handling after receipt .....	3
2.2. Taking off the Cover (4).....	4
2.3. Installation .....	4
2.4. Filling .....	5
2.5. Connection of the Tubing .....	5
<b>3. Measurement.....</b>	<b>5</b>
3.1. Measurement principle .....	5
3.2. Factory Calibration/Calibration Factor.....	6
3.3. Influence of Particles (Dirt & Dust) in the Gas Flow .....	6
3.4. Effect of Temperature.....	6
3.5. Effect of System Gas Pressure .....	7
3.6. Effect of Water Vapour Partial Pressure .....	7
3.7. Temperature and Pressure Corrections.....	7
3.8. Special Features with Fermentation Tests .....	8
<b>4. Counter unit .....</b>	<b>9</b>
4.1. Display .....	9
4.2. Reset Button .....	9
4.3. Signal Output .....	9
4.3.1. Reed Switch .....	9
4.3.2. Output Socket .....	10
<b>5. Maintenance .....</b>	<b>11</b>
5.1. Checking the Packing liquid Level.....	11
5.2. Cleaning of the Micro Capillary Tube .....	11
5.3. Exchange of Battery of the Counter Unit.....	11
5.4. Disassembly / Exchange of the Measurement Cell.....	12
5.5. Long-term Storage .....	13

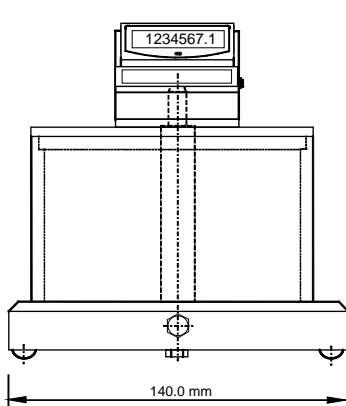

Front View

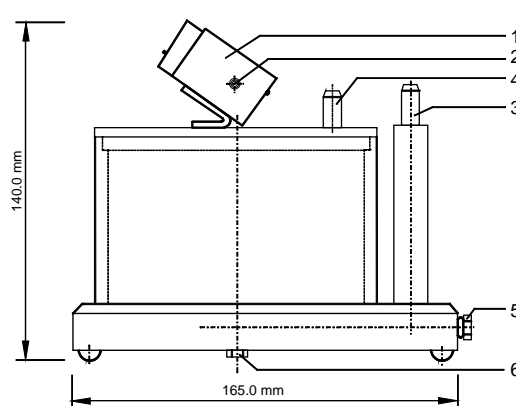

Side View

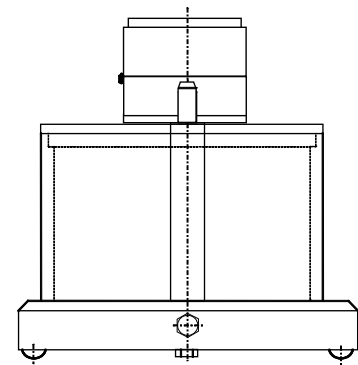

Rear View

- (1) Digit Display
- (2) Signal Output (reed contact)

- (3) Gas Inlet
- (4) Gas Outlet

- (5) Screw plug gas inlet channel
- (6) Screw plug micro capillary

## 1. Data Sheet

### Performance Specifications

Minimum Flow Rate $Q_{\min}$	0.5	ltr/h	Maximum gas inlet pressure	<b>50 mbar</b>
Maximum Flow Rate $Q_{\max}$	6	ltr/h	Minimum gas inlet pressure	8 mbar
Measuring Accuracy	$\pm 3$	%	Gas inlet pressure at measurement start, approx. <sup>3)</sup>	10 mbar
Measuring resolution <sup>1)</sup>	10	ml	Connection gas in/outlet	nozzle
Minimum indication <sup>2)</sup>	0.1	ml	Nozzle outer diameter	8 mm
Packing Liquid quantity, approx.	500	ml		

<sup>1)</sup> = norm volume of measuring chamber

<sup>2)</sup> Because of calibration factor with 1 decimal

<sup>3)</sup> Higher gas inlet pressure until gas inlet channel and micro capillary in the base plate are clear of packing liquid

### Material

Base, casing, connection nozzles:	Plexiglass (PMMA)
Measurement cell:	Polycarbonate (PC)

### Standard Equipment

Electronic counter / LED display	Gas inlet / outlet nozzles
Display: 6 digits [ml] + 2 decimals	Cleaning rod for micro capillary
Signal output (reed contact), floating output, 0,1 msec, maximum load 30 V DC / 0.33 A	Cover opening tool
Twin-chamber measurement cell	1 ltr. packing liquid
	1.5 m gas connection tubing (PVC)

### Accessories

Packing liquid 100 / 500 / 1,000 ml	Gas connection tubing (PVC)
-------------------------------------	-----------------------------

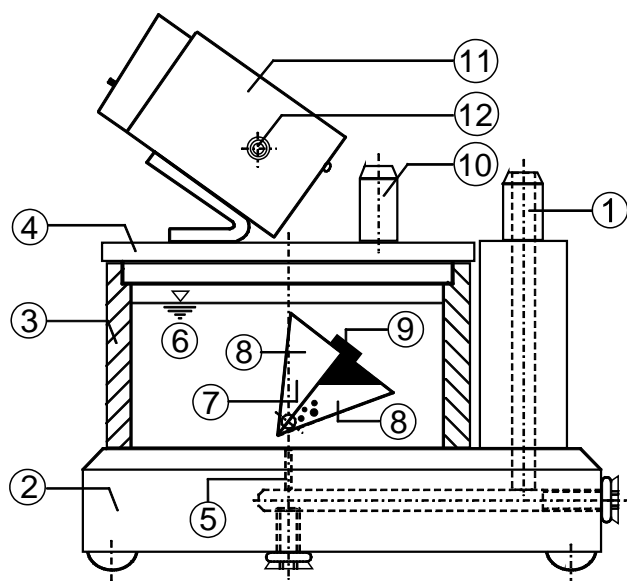

**Casing Components**

- (1) Gas inlet nozzle
- (2) Base plate
- (3) Liquid container
- (4) Cover
- (5) Micro capillary tube
- (6) Packing liquid
- (7) Measurement cell (tilting body)
- (8) Two measurement chambers
- (9) Permanent magnet
- (10) Gas outlet nozzle
- (11) Counter unit including LCD display
- (12) Socket Reed Contact

## 2. Initial Operation

### 2.1. Handling after receipt

- a) Each MilliGascounter was calibrated individually and expensively and therefore is a precision-measuring instrument. Please read this operation instructions carefully to guarantee a long and trouble-free operation.
- b) Unpack the MilliGascounter carefully. The box contains:
  - 1 MilliGascounter
  - 1 bottle of packing liquid (1 ltr.)
  - 1.5 m tubing
  - 1 cover opening tool (PMMA block with 2 rounded edges)
  - 1 cleaning tool (PMMA rod with inserted wire)
- c) For protection during transport **the measurement cell (7) is blocked by a piece of foam plastic which must be removed.** To do this, please take off the cover (4)<sup>1</sup> of the liquid container together with the counter (11). **Please do not pick up the cover by the counter (11)** because it might break off its support.

Remove the foam plastic piece **carefully** without damaging the **fragile** measurement cell (7).

Recommendation: Once the cover is removed, the liquid container can be filled with the packing liquid following the instructions in point 2.4. After filling, please proceed with the following paragraph.

**Please note:** The correct position (in rotational direction) of the cover relative to the casing is very important! For first rough orientation, the gas inlet nozzle (1) and outlet nozzle (10) must be next to each other. For fine adjustment, the fine engraved lines on top of both nozzles must be in true alignment. **A wrong cover position might result**

<sup>1</sup> For taking off the cover, by all means please mind the instructions in par. 2.2

**in faulty measurements** because the sensor (reed contact inside of the cover) might get no magnetic pulse from the permanent magnet (9).

Replace the cover by gently but firmly pressing it down into the MilliGascounter casing.

## 2.2. Taking off the Cover (4)

In order to ensure gas and liquid tightness of the liquid container of the casing, the cover is sealed by an O-ring (Viton). Over the time, the O-ring might stick to the container so that a certain force is needed to overcome the surface adhesion between O-ring and container.

- **Please do not pick up the cover by the counter (11)** because it might break off its support.
- Use the provided tool for opening of the cover **only** according to the following instructions. **Do not use tools like screw drivers** etc.

For easier opening of the liquid container the cover has been made slightly larger in diameter than the container. If the container cannot be opened by taking off the cover by hand,

- place the opening tool onto the base plate (2) of the MGC at one of its rear corners so that a sharp edge of the opening tool is located under the overlapping cover (see graphic).
- push the lower end of the tool towards the liquid container which will partly lift the cover.
- If the cover still cannot be taken off, please repeat this procedure at another corner of the MGC.

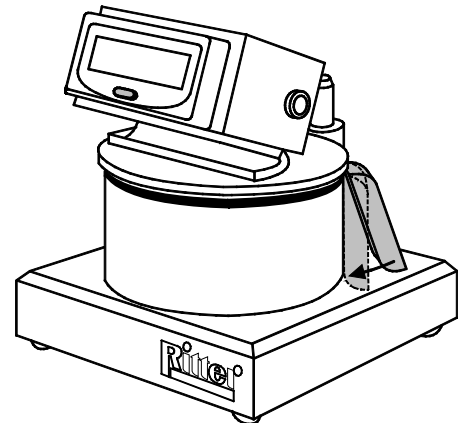

## 2.3. Installation

- a) The MilliGascounter should be installed on a horizontal, solid and vibration-free base.
- b) If the gas to be measured contains water vapour or an other condensable gas, it is necessary to make sure that the gas does not condense inside the MilliGascounter. This can be achieved through *cooling* the gas to room temperature before-hand or through using a *condensation trap*. The easiest way to cool the gas is to use proportionately longer feeder tubing or a metal pipe (e.g. 20 cm long); if necessary, the feeder tubing can be passed through a water bath.

If condensation cannot be avoided, the MilliGascounter should be installed in such a way, that the condensation present in the feeder tubing cannot flow into it<sup>2</sup>. At the same time such a condensation trap also prevents the reverse, i.e. it prevents the packing liquid from flowing backwards into the gas supply line or to the gas source (fermentation tank). This can occur as a result of a drop in temperature within the gas source/gas supply line system (fermentation equipment) creating an under-pressure.

<sup>2</sup> We recommend the use of condensation traps when the MilliGascounter is connected to a fermentation tank, and in particular with thermophilic fermentation processes. A lot of water vapour can escape particularly in those cases.

Simple condensation traps such as these can be supplied upon request. If condensation gets into the MilliGascounter nevertheless, it will collect at the bottom of the packing liquid casing and can be siphoned off with a pipette.

## 2.4. Filling

Only the special packing liquid delivered with the MilliGascounter should be used to fill it, as the calibration is only valid with this packing liquid. (If a hydrous liquid is used, unavoidable measurement errors will occur due to the higher surface tension.)

Filling can be carried out either by removing the cover or by using a pipette to fill it through the gas outlet nozzle (10). The MilliGascounter casing must be filled to the engraved ring-shaped division mark which ensures that the packing liquid completely covers the measurement chambers (8). Approximately 0.5 ltr is needed.

The packing liquid is physiologically safe. Because it is an oily polymer, stains on clothing can be treated the same as oil stains.

## 2.5. Connection of the Tubing

The tubing has to be connected to the gas inlet nozzle (1) and if necessary, to the gas outlet nozzle (10) of the MilliGascounter.

Please use gas-tight tubing for connection to the MilliGascounter<sup>3</sup>. Silicone tubing is therefore not suitable and simple rubber tubing is only conditionally suitable. We recommend Perbunan-Nitrile- or PVC-Tubing<sup>4</sup> with a wall thickness of 1.5 mm and 7 mm inner diameter.

## 3. Measurement

### 3.1. Measurement principle

The gas to be measured flows in via the gas inlet nozzle (1), through the micro capillary tube (5) located in the base of the MilliGascounter and up into the liquid casing which is filled with a packing liquid (6).

The gas rises as small gas bubbles through the packing liquid, up and into the measurement cell (7). The measurement cell consists of two measuring chambers (8), which are filled alternatively by the rising gas bubbles. When a measuring chamber is full, the buoyancy of the filled chamber causes the measurement cell to abruptly tip over into such a position that the second measuring chamber begins to fill and the first empties.

The measurement of gas volume therefore occurs in discrete steps by counting the tilts of the measurement cell (7) with a resolution of approximately 10 ml (= contents of a measuring chamber, please refer to Point 2.2). This "residual error" (= max. 10 ml) caused

---

<sup>3</sup> When the MilliGascounter is to be attached to a fermentation tank, a glass tube a few centimeters long can be used as a coupling between the fermentation tank and the MilliGascounter.

(Plastic couplings often have casting seams which can lead to leakage).

<sup>4</sup> 0.5 m of tubing is included as standard equipment and is therefore delivered with the unit.

by the resolution should be taken into account when estimating/calculating the total measurement error.

Through the combination of a permanent magnet (9) and a magnetic sensor (reed contact), this tilting procedure creates a pulse which is registered by the counter unit (11).

The measured gas escapes through the gas outlet nozzle (10).

The switching pulses of the reed contact can be obtained via the socket (12). (please refer to Point 3.3).

### 3.2. Factory Calibration/Calibration Factor

Because of the manufacturing tolerances, the exact volume of a measurement cell is generally  $\neq 10.0$  ml. The difference from the norm-value of 10.0 ml (= measurement error) is determined at time of calibration. This calibration factor

- is noted in the calibration protocol,
- is programmed into the counter unit. This means that the measured volume (= number of tilts of the measuring cells) is multiplied by the programmed Calibration Factor and the result is displayed. The counter unit therefore displays the „true“ volume of the gas in ml.

### 3.3. Influence of Particles (Dirt & Dust) in the Gas Flow

If the gas flow in the incoming tubes or in the micro capillary tube is obstructed by particles or liquid, the calibration factor will be affected. Therefore, dust particles have to be absorbed by a suitable filter and the insides of the incoming tubes must be dry.

### 3.4. Effect of Temperature

Because of the extreme resolution of the MilliGascounter in the milli-liter-range, „volume flows“ can also be registered as a consequence of changes in temperature. A temperature rise [or decrease] at the gas source or respectively in the supply system causes an expansion [or contraction] of the gas present in the system proportional to its volume. Whereas an expansion of the gas generates a „virtual“ gas flow (with an corresponding display at the counter unit), a contraction causes an under-pressure in the supply system. This under-pressure enables packing liquid to flow through the micro capillary tube into the gas feeder tubing. Packing liquid in the gas feeder tubing causes

- ⇒ an increased admission pressure,
- ⇒ a time delay until the first display on the counter unit (until the micro capillary tubing is once again free of packing liquid),
- ⇒ erroneous measurement deviations.

No actual measurement should therefore be started until the temperature of the total system has been adjusted<sup>5</sup>. An expansion of the gas during adjustment of the temperature and the subsequent build-up of an overpressure can simultaneously be used as an operational check of the MilliGascounter (description of the Reset Button, please refer to Point 3.2).

The room temperature should remain approximately the same during the whole of the measurement period (be careful of temperature decreases during the night and over the

<sup>5</sup> With fermentation tests: After equalization with the fermentation temperature.

weekend), otherwise the temperature has to be monitored so that an integrating correction of the measurement values can be made (please refer also to: „Temperature- and Pressure corrections“). Another alternative is the installation of the MilliGascounter, gas feeder tubing and gas source in a temperature-controlled cupboard.

### 3.5. Effect of System Gas Pressure

A rise [decrease] in pressure in the gas source or respectively in the gas supply system causes an expansion [contraction] of the gas present, proportional to its volume. The same therefore applies to air pressure as was mentioned in the previous Section on the Effect of Temperature.

### 3.6. Effect of Water Vapour Partial Pressure<sup>6</sup>

If the measurement result has to be corrected for the volumetric share of water vapour, the values in the following Table 1 which take temperature into account, can be used in the equation listed under Point 2.6.

Temp. °C	Water vapour partial pressure mbar (psi)	Temp. °C	Water vapour partial pressure mbar (psi)	Temp. °C	Water vapour partial pressure mbar (psi)
15	17.0 (0.246)	20	23.4 (0.339)	25	31.7 (0.459)
16	18.1 (0.262)	21	24.9 (0.361)	30	42.6 (0.617)
17	19.4 (0.281)	22	26.4 (.0383)	35	56.4 (0.817)
18	20.6 (0.299)	23	28.1 (0.407)	40	73.9 (1.071)
19	22.0 (0.319)	24	29.9 (0.433)	45	95.9 (1.390)

Table 1: Values of water vapour partial pressure

### 3.7. Temperature and Pressure Corrections

The MilliGascounter is a volumetric gas meter and therefore measures gas volume in the actual operating state existing at the time of measurement. The gas volume is dependent on gas temperature, air pressure and water vapour partial pressure (for water vapour partial pressure refer to footnote „6“). These measurable variables are therefore needed to recalculate to norm conditions. The gas temperature is to be measured at the gas **outlet**.

<sup>6</sup> The information in Point 2.5 is valid only for gases which contain water vapour **and** if the volume of the water vapour **must be** mathematically eliminated from the measurement result. If the water vapour is a „natural“ element of the gas and its volume should therefore be taken into account, then no (partial-)pressure correction should be carried out. In that case,  $p_v = 0$  must be used in the equation listed under Point 2.6.

According to the general gas laws the following equation is used for temperature and pressure corrections:

$$V_N = V_i \times \frac{P_a - P_V + P_L}{P_N} \times \frac{T_N}{T_a}$$

whereby	$V_N$	=	Norm-Volume	in	[ml]
	$V_i$	=	Indicated (displayed) Volume	in	[ml]
	$P_a$	=	Actual Air Pressure	in	[mbar-absolute]
	$P_V$	=	Water vapour partial pressure	in	[mbar]
	$P_L$	=	Pressure of the Liquid Column above the Measurement Chamber = 2		[mbar]
	$P_N$	=	Norm-Pressure =	1013,25	[mbar]
	$T_N$	=	Norm-Temperature =	273,15	[Kelvin]
	$T_a$	=	Actual Temperature	in	[Kelvin]

If the exact air pressure is not known, the norm-pressure can in that case be used. Air pressure swings of 980 - 1050hPa create errors in the range of -2,6% to +5%.

### 3.8. Special Features with Fermentation Tests

- In incubators without compulsory ventilation, uneven temperature distribution can cause underpressure in the reaction vessels.
- The free volume in the fermentation tank and in the feeder tubing to the MilliGascounter should not be smaller than 0.5 ltr. This volume acts as a buffer volume with both eruptively running fermentation processes and reduction of temperature to prevent the generation of underpressure. Because of this, only tanks which have a free volume of at least 0.5 liters above the test material should be used.
- To determine the total gas production as accurately as possible, it is advisable to leaven the released CO<sub>2</sub> in the fermentation tank to pH 1-2 after the fermentation test has ended. However, this can lead to foam formation and wetting of the tubing.
- The MilliGascounter was calibrated at room temperature (21°C). If the in-house standard temperature is 21°C as well (instead of the international standard of 0°C / 273.15 K), the temperature correction is not necessary when the gas is cooled down to 21°C. With a fermentation temperature of 37°C this is obtained when using a connecting tubing with a length of 1.5 m.
- If the biogas contains high amounts of ammonium and H<sub>2</sub>S the possibility increases, that the micro capillary of the gas inlet pipe plugs. In such a case it is recommended to install an absorber flask in the gas tubing to the MilliGascounter. This absorber flask can content ferric iron pebbles (ferrous oxide). Hydrogen sulphide will be linked to the ferric iron pebbles. But such an absorber flask can also content that kind of charcoal, which is used also e.g. in kitchen hoods. If the medium in the absorber flask is used up (recognised by the smell or if there is no cleaning effect any more) the medium has to be replaced.

- Experiments to determine the methanogenic potential of organic substances in the laboratory of Prof. Dr. Paul Scherer<sup>7</sup> (University of Applied Sciences Hamburg, Paul.Scherer@rzbd.haw-hamburg.de) have shown that the dry matter content of the seed sludge has not only an influence on the velocity of the gas production, but also on the total amount of produced gas. Of course in all cases parallel to the gas production of a test substance a reference without added organics was subtracted. Based on these findings it is recommended to use in such experiments at least 3% dry matter content of a seed sludge. It is important to homogenize the sludge by a mixer before use. It is also of importance that thickened sewage sludge often contains small amounts of polymers to support the coagulation. But added polymers often contain substantial amounts of biodegradable alkanes to facilitate the addition. These additives increase the background production of biogas during a test period. If the background production of biogas is too high this could complicate the calculation of the gas production of the test substance.

But if the gas production of the seed sludge is too low then in some situations it can occur that the pressure in the test flasks drops down below the atmospheric pressure. According to the principle of connected tubes this can lead to a flow of oily packing liquid into the test trial vessel. In such cases it is recommended to increase the background gas production by the addition of cellulose powder (e.g., Avicel). Also the test approach should be started at room temperature so that the temperature in the incubators (mostly 35-37°C) increases smoothly generating thereby a small overpressure.

## 4. Counter unit

### 4.1. Display

Gas volume is displayed in milli-liters (6 digits) with a resolution of 0.1 ml. The calibration factor resulting from the calibration is programmed into the counter unit. This means that the measured volume (= number of tilts of the measuring cells) is multiplied by the programmed calibration factor and the result is displayed. The counter unit therefore displays the „true“ volume of the gas in ml and not the number of tilts.

### 4.2. Reset Button

The blue reset button is located under the digital display. A press of the reset button erases the measurement value memory and sets the display back to zero. The calibration factor remains preserved in the counter unit.

### 4.3. Signal Output

#### 4.3.1. Reed Switch

- **Function:**

The measurement of the flowing gas volume occurs by counting the number of tilts of the measurement cell (7) by means of a permanent magnet (9) and two magnetic sensors (reed contacts). The magnet is located at the top of the

---

<sup>7</sup> Scherer, P.A. (2001) Influence of high solid content on anaerobic degradation tests measured online by a MilliGascounter® station for biogas. In: Proceedings of the 9<sup>th</sup> World Congress on “Anaerobic Digestion 2001” (L. van Velsen, W. Verstraete, Eds.), Antwerpen.

measurement cell, the reed contacts are located within the cover on top of the casing.

The tilting procedure of the measurement cell closes the two reed contacts. The first reed contact initiates a counter pulse at the counter mechanism (11). Additionally, the pulse of the second reed contact can be used as a signal output from the MilliGascounter to an external data acquisition system. Please note that **display** shows the **true gas volume** (i.e. the measured volume multiplied by the calibration volume) whereas the **pulses** counted at the **output socket** are equivalent to the number of tilts and hereby equal to the **uncorrected (not calibrated) gas volume**.

The reed contact of the signal output works as a potential-free closing contact with a switch-/closing time of about 0.1 sec.

- **Electrical Data:**

Max. switching power	10	Watt
Max. switching current	0.5	A/DC
Max. switching voltage	200	V/DC
Rebound time	< 1	msec
Max. switched contact resistance	150	mOhm

#### 4.3.2. Output Socket

The switching pulses of the reed contact can be obtained at the output socket (12).

**Attention:** The switch pulses of the reed contact are equal to the number of tilts of the measurement cell. The pulses therefore represent the uncorrected (not calibrated) measured gas volume. The gas volume obtained via the signal output socket must therefore be multiplied by the calibration factor to get the true gas volume.

The output socket is a standard 3.5 mm stereo socket, into which a compatible jack plug can be inserted (identical to a jack plug of walkman cassette players).

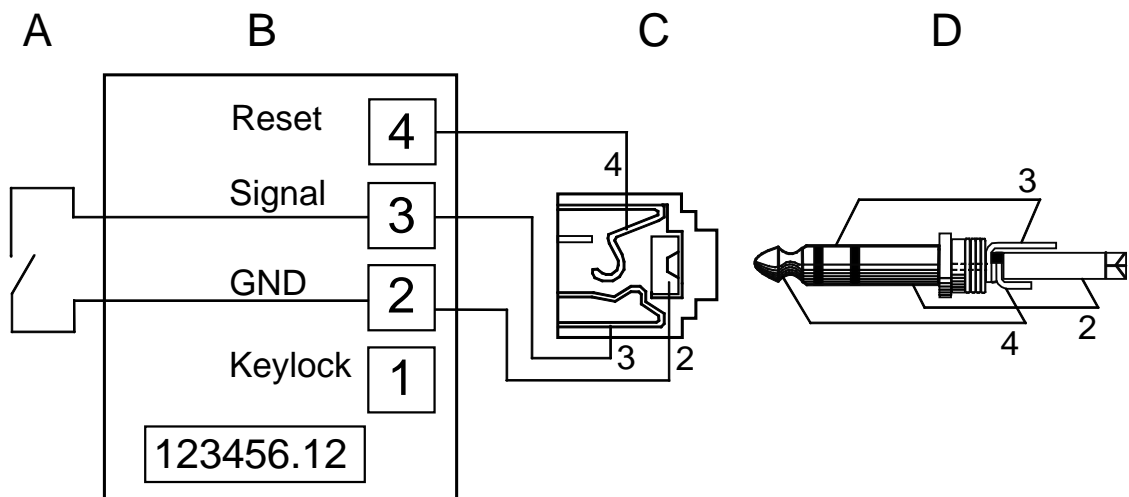

Legend:

Part	Function
A	Reed Contact no. 1 for counter
B	Counter and LCD display
C	Reed Contact no. 2 for output signal and Output Socket
D	Jack plug (3.5 mm stereo socket)

Pin / Contact of Jack Plug	Function
1	Not used
2	Ground
3	Signal
4	Not used

## 5. Maintenance

### 5.1. Checking the Packing liquid Level

The rate of evaporation of the packing liquid in the MilliGascounter is very slow but dependant upon the gas flow rate as well as the operating temperature. Also the diameter of the gas outlet nozzle contributes to it. Therefore the evaporation can be diminished even more by closing the outlet with a stopper and piercing it with a syringe needle. To ensure a stable measurement accuracy therefore, the packing liquid level (the engraved ring-shaped division mark on the casing of the MilliGascounter) must be checked from time to time. In all events, the measurement cell has to be completely submerged under the packing liquid surface during the tilting procedure.

### 5.2. Cleaning of the Micro Capillary Tube

The free cross-section of the micro capillary outlet (5) on the bottom of the liquid container has a substantial influence on the measurement accuracy. A narrowed gas outlet primarily influences the gas pressure, which can then also increase to over 30 mbar in the gas supply lines and cause a pulsating gas flow. This leads to erroneous measurement deviations. The micro capillary tubing should therefore be cleaned occasionally.

- To do this, empty the MilliGascounter either by taking off the lid and pouring out the packing liquid or by sucking it out through the gas outlet nozzle (10) with a pipette.
- Remove the closing screw of the micro capillary tube (5) under the MilliGascounter base plate.
- The micro capillary should only be cleaned with the cleaning rod containing a fine wire delivered for this purpose with the MilliGascounter. A wire with a smaller diameter would not have the desired cleaning effect, a larger diameter could enlarge the micro capillary and consequently lead to an alteration in the calibration.
- Finally close the micro capillary again with the closing screw and fill the MilliGascounter with packing liquid as described in Point 1.2.

### 5.3. Exchange of Battery of the Counter Unit

The counter unit is equipped with a lithium battery (2 V) with a working life of 4 to 5 years (no responsibility is taken for the correctness of this information<sup>8</sup>). Unfortunately, the battery cannot be exchanged easily because it is welded to its support. Furthermore, the programmed calibration factor is erased when the battery is removed. Special hardware

<sup>8</sup> Besides tolerances during manufacturing the storage and working temperature of the battery / MilliGascounter affects the working life.

and software equipment is required to reprogram the calibration factor, which means that the reprogramming can only be done by the manufacturer.

The following alternatives exist for a battery change:

- Disassembly of the counter unit (see below) and return to the manufacturer.
- An exchange counter with a new battery unit can be ordered from the manufacturer and exchanged with the existing one. The exchange counter unit will be programmed with the calibration factor of the existing MilliGascounter. After having exchanged the counter units return of the old unit to the manufacturer.

Please Note: To ensure an uninterrupted use of the MilliGascounter, an exchange counter unit should be ordered before the existing battery is completely discharged - for example after 4 years of operation.

- The complete MilliGascounter can be sent back to the manufacturer.

Disassembly of the counter unit:

- Unscrew the fastening screw on the rear side of the counter unit casing (11).
- Pull the inner counter unit gently out of the casing as far as it possible due to the connected leads.
- Take off the leads by unscrewing the terminal screws.

The assembly of the new unit is performed according to the instructions enclosed to the unit.

#### 5.4. Disassembly / Exchange of the Measurement Cell

If it should become necessary to exchange the measurement cell, it is recommended to return the whole unit to the manufacturer. If this is not possible or if it is uneconomical, the measurement cell can be exchanged as follows:

- The casing cover must be removed (see par. 2.2) as well as the packing liquid (and respectively poured out).
- The measurement cell (7) is hold in its position in the bearing blocks on both sides of the measurement cell with two screws (hexagon socket set screws M3). One of this screws must be loosened so that the measurement cell can be removed.
- The assembly of the new measurement cell must be done in reverse sequence. **Please note:** When tightening the bearing screw, the bearing pin (head of bearing screw) must be located inside of the bearing but must not block the bearing.

After the assembly is completed, it is recommended to perform the following function tests:

- Sufficient fixing: Lift the whole MilliGascounter from its support by holding the measurement cell at both sides of the middle partition wall between two fingers. Even when gently swinging the MilliGascounter, the measurement cell should remain in its position.

- Free swinging: Hold the MilliGascounter upside down and swing the whole unit. The measurement cell should swing free and easily.

#### **5.5. Long-term Storage**

The permanent magnet on top of the measurement cell is not resistant to corrosion. When not needed, store the MilliGascounter therefore either completely dry and airtight (both connection nozzles closed) or filled with packing liquid.